

MIG (GMAW) torches M-SYSTEM® G.400 / G.400-360°

CONFIGURATIONS AND TECHNICAL DATA



Code	Icon	↔		Icon
MA4106-030	M-SYSTEM G.400	3 m	10'	EURO - TW
MA4106-040	M-SYSTEM G.400	4 m	12'	
MA4106-046	M-SYSTEM G.400	4,6 m	15'	
MA4108-046	M-SYSTEM G.400-360°	4,6 m	15'	

Code	Icon	↔		Icon
MA4107-030	M-SYSTEM G.400	3 m	10'	5/8-18 UNF
MA4107-040	M-SYSTEM G.400	4 m	12'	
MA4107-046	M-SYSTEM G.400	4,6 m	15'	
MA4109-046	M-SYSTEM G.400-360°	4,6 m	15'	

+

Code	Icon	Code	Icon
AR0170	Tweco® 1-4 kit	AR0176	Lincoln® "L4" kit
AR0171	Tweco® 5 kit	AR0177	Lincoln® "L2" kit
AR0172	Lincoln® "L" kit	AR0178	Lincoln® "L3" kit
AR0173	Miller® "M" kit	AR0179	Lincoln® "L1" kit



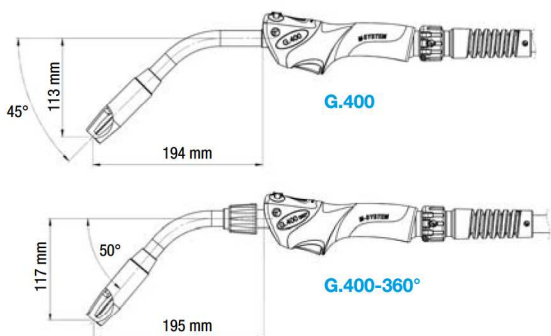



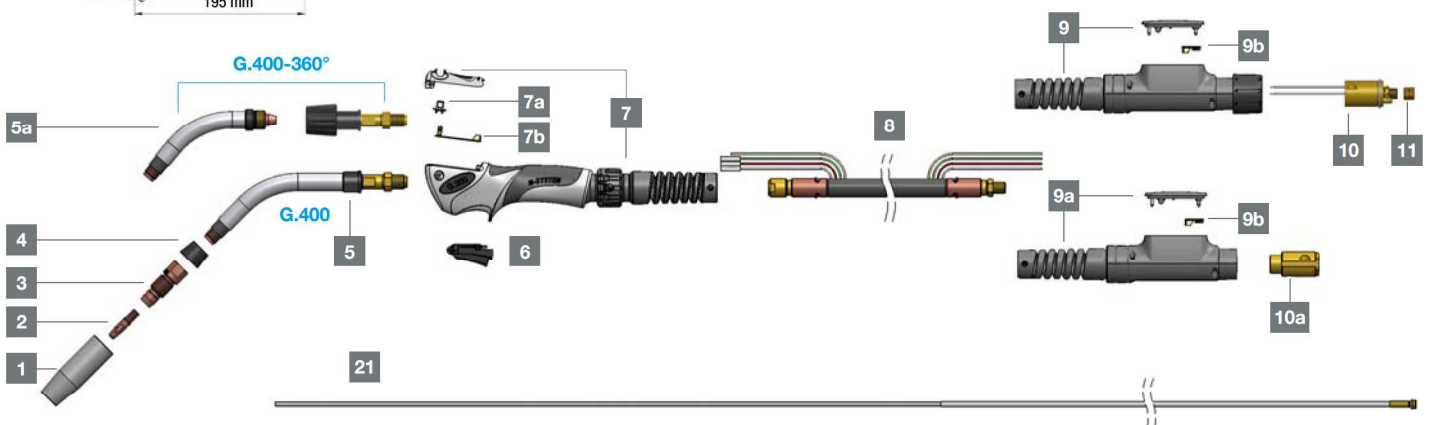

KIT to be assembled by a qualified technician.
See all details on page 27.

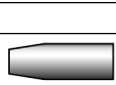
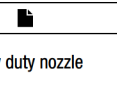





















Icon	M-SYSTEM G.400		M-SYSTEM G.400-360°	
	1,7 kg	3,7 lb	1,8 kg	4,0 lb
	113		113	
	0,8 ÷ 2,4 mm	.030" ÷ 3/32"	0,8 ÷ 2,4 mm	.030" ÷ 3/32"0
	450A CO ₂ - 400A Mix		450A CO ₂ - 400A Mix	







WEAR AND SPARE PARTS

	Code			Ø		↔		Ref	
1	MC0298		heavy duty nozzle	14 mm	9/16"	82 mm	3-7/32"	-	5
1	MC0011		heavy duty nozzle	16 mm	5/8"	82 mm	3-7/32"	-	5
1	MC0012		heavy duty nozzle	18 mm	23/32"	82 mm	3-7/32"	-	5
1	MC0013		heavy duty nozzle	20 mm	25/32"	82 mm	3-7/32"	-	5
2	MD0250-60		M9x1 - Cu for aluminium	1,0 mm	.040"	38 mm	1"-1/2	-	20
2	MD0250-62		M9x1 - Cu for aluminium	1,2 mm	.045"	38 mm	1"-1/2	-	20
2	MD0250-66		M9x1 - Cu for aluminium	1,6 mm	1/16"	38 mm	1"-1/2	-	20
2	MD0250-78		M9x1 - CuCrZr	0,8 mm	.030"	38 mm	1"-1/2	-	20
2	MD0250-79		M9x1 - CuCrZr	0,9 mm	.035"	38 mm	1"-1/2	-	20
2	MD0250-80		M9x1 - CuCrZr	1,0 mm	.040"	38 mm	1"-1/2	-	20
2	MD0250-82		M9x1 - CuCrZr	1,2 mm	.045"	38 mm	1"-1/2	-	20
2	MD0250-84		M9x1 - CuCrZr	1,4 mm	.052"	38 mm	1"-1/2	-	20
2	MD0250-86		M9x1 - CuCrZr	1,6 mm	1/16"	38 mm	1"-1/2	-	20
2	MD0250-90		M9x1 - CuCrZr	2,0 mm	5/64"	38 mm	1"-1/2	-	20
2	MD0250-94	M9x1 - CuCrZr	2,4 mm	3/32"	38 mm	1"-1/2	-	20	
3	ME0601		M9x1 copper diffuser			54 mm	2-1/8"	-	5
21	GM0013		grey steel liner for 5/8-18 UNF connection	1,2 ÷ 1,6 mm	.045" ÷ 1/16"	5 m	16.4'	44-116-15	1

	Code		
4	MQ0394		insulator 1
5	MF0503		torch head 1
6	BX1340		trigger 1
7	MT0358		handle kit 1
7a	MT0359		FLASH PROTECT spare lenses kit (5 pcs.) 1
7b	MT0360		FLASH PROTECT board kit handle side 1
8	MH0802-030		coaxial cable - 3 m / 10' 1
8	MH0802-040		coaxial cable - 4 m / 12' 1
8	MH0802-046		coaxial cable - 4,6 m / 15' 1

	Code		
9	MT0355		back housing assembly kit for EURO connection 1
9	BW1301		EURO connection nut 1
9b	MT0357		FLASH PROTECT board kit back box side 1
10	AR0255		EURO TW connector 1
11	FA0027		liner nut M11x1 10
9a	MT0356		back housing assembly kit for 5/8-18 UNF connection 1
10a	FB0395		5/8-18 UNF power connector 1
	BX1294		FLASH PROTECT battery holder (4xAA not included) 1

ONLY FOR G.400-360°

	Code		
5a	MF0502		rotating torch head 1
5a	MT0361		fixed side kit for rotating torch head 1

STANDARD

KITS FOR 5/8-18 UNF CONNECTOR

Complete connection kits for machines with American-type connections.
Kits to be assembled on torches with 5/8-18 UNF connectors.

TWECO® 1-4 COMPLETE CONNECTION KIT

Code		
AR0170		Tweco® 1-4 complete connection Kit

TWECO® 5 COMPLETE CONNECTION KIT

Code		
AR0171		Tweco® 5 complete connection Kit

Only for Tweco® 5

“L” LINCOLN® COMPLETE CONNECTION KIT

Code		
AR0172		“L” Lincoln® complete connection Kit

Suitable for Lincoln® Wire Feeders and machines SP150, SP200, LN7, LN8, LN25, LN742, Synergic 7, LN10, DH10 and for LF-72 and LF-74 Wire Feeders

“L1” LINCOLN® COMPLETE CONNECTION KIT

Code		
AR0179		“L1” Lincoln® complete connection Kit

Suitable for Lincoln SP140C and SP180C

“L2” LINCOLN® COMPLETE CONNECTION KIT

Code		
AR0177		“L2” Lincoln® complete connection Kit

Suitable for Lincoln® Powermig and Wirematic systems

“L3” LINCOLN® COMPLETE CONNECTION KIT

Code		
AR0178		“L3” Lincoln® complete connection Kit

Suitable for Lincoln® Wire Feeders: LF-72, LF-74, Power Feed® M10M, LN-10, DH10, STT-10, LN-15, Power Feed® M15, LN-25 Pro, Power Feed® 25M

“L4” LINCOLN® COMPLETE CONNECTION KIT

Code		
AR0176		“L4” Lincoln® complete connection Kit

Suitable for Lincoln® SP140T and SP180T

“M” MILLER® COMPLETE CONNECTION KIT

Code		
AR0173		“M” Miller® complete connection Kit

Suitable for most Miller® Wire Feeders and compact welding machines

LEGEND

	Code
	Description
	Length
	Connection
	Pack quantity
	Air cooling
	Water cooling

	Weight at 1 metre high
	V PEAK Voltage
	Ø Wire diameter
	X 60% Duty cycle amperage
	X 100% Duty cycle amperage
	☼ Cooling liquid maximum pressure
	☼ ↓ Cooling liquid minimum flow rate

	Ø Diameter
	Ø INT Internal diameter
	Ø EXT External diameter
	○ RING O-ring
	▬ Fixed head
	▬ Passing head
	Ref International reference